

## Vacuum Generators



### Features

- ▶ Stainless Steel 316L construction
- ▶ Cleaned, welded assembled, tested and packaged in Class 10 clean room
- ▶ Internal Surface Finish 0.4  $\mu$ m
- ▶ 660 mmHg (100 Torr) vacuum generated with a minimum source nitrogen pressure of 75 psig
- ▶ Helium leak tested
- ▶ Used in gas delivery systems to assist in purging piping systems.

### Dimensions

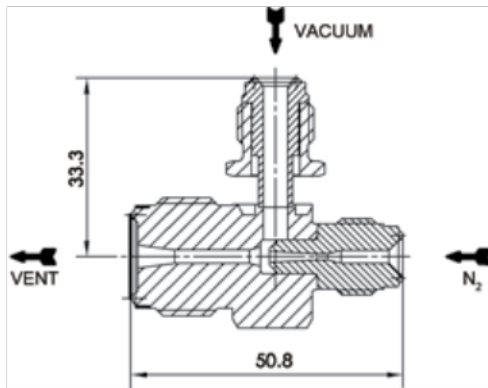

### Vacuum Chart

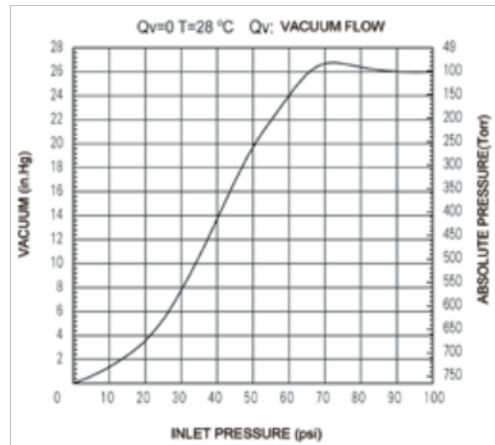

### Ordering Information

EX:	SL	- VG22	- VM4	- VM4	- VM8	Connections
	BODY	Series	N <sub>2</sub> Inlet	Vent Connections	Vacuum Connections	
	SL: 316L	VG22	VM4	VM4 VM8	VM4 VSM4 VSF4 TW4	VM4: 1/4" face seal male VM8: 1/2" face seal male VSM4: 1/4" face seal swivel male VSF4: 1/4" face seal swivel female TW4: 1/4" tube weld